

## MULTISTREAM 10-35

### SEWAGE PUMPS



MULTISTREAM



#### FEATURES

- Adjustable single-channel impeller.
- Safe to run dry.
- SiC mechanical seal.
- Moisture-sealed cable inlet.
- Controllable oil chamber.
- Built-in motor protection.
- Max. head - 27 m.
- Max. flow - 2200 lpm.

#### APPLICATIONS

- Recommended for:
- effluent which contains fiborous matter
  - effluent which contains solids
  - mixed water
  - raw effluent
  - raw sludge
  - rainwater.

#### PUMP INFORMATION

The adjustable axial gap of the MultiStream pump makes it possible to re-optimize the efficiency in case of abrasion by adjusting only one single screw. This can be done cost-effectively when the maintenance is carried out and the pumps keeps its optimum performance on a long-term basis.

#### PUMP CONSTRUCTION MATERIALS

Vertical, single-stage, submersible with horizontal discharge flange, single channel impeller and short shaft extension, providing a longer service life of the ball bearings and mechanical seal.

- Pump casing:** Grey cast iron.
- Motor housing:** Grey cast iron.
- Impeller:** Grey cast iron.
- Mechanical seal:** Silicon carbide mechanical seal with oil chamber and artificial carbon mechanical (or duplex rotary shaft seal up to size 35) as secondary seal.

#### OPERATING CONDITIONS

Install the pump vertically with guide rail system or pump base. Operate in conditions where the material to be transported is up to 40°C. Continuous operation where the motor is submerged. Intermittent operation where the motor is emerged (S3). E.g. 35%= 3.5 min. operation, 6.5 min. break.

#### SCOPE OF SUPPLY

Pump with 10 m cable, without plug, without pump base.

## ELECTRICAL DATA

Type	Type of current	Voltage $\pm 10\%$	Frequency Hz	Motor rating kW		S3 %	RPM min	Current ampere	Motor protection	IP rating	Device fuse min.
				P1	P2						
10/2 A1	3-phase	230 / 400	50	1.30	1.10	60	2943	4.6 / 2.7 A	Thermostat	68	10 A
15/2 A1	3-phase	230 / 400	50	1.80	1.50	50	2910	5.7 / 3.3 A	Thermostat	68	10 A
25/2 A2	3-phase	230 / 400	50	2.60	2.10	40	2860	7.6 / 4.4 A	Thermostat	68	10 A
35/2 A2	3-phase	230 / 400	50	3.70	3.04	40	2895	11.5 / 6.6 A	Thermostat	68	10 A
25/2 B1	3-phase	230 / 400	50	2.60	2.10	40	2860	7.6 / 4.4 A	Thermostat	68	10 A
35/2 B2	3-phase	230 / 400	50	3.70	3.04	40	2895	11.5 / 6.6 A	Thermostat	68	10 A
10/4 B1	3-phase	230 / 400	50	0.95	0.73	50	1446	4.2 / 2.4 A	Thermostat	68	10 A
15/4 B3	3-phase	230 / 400	50	1.80	1.40	40	1426	5.9 / 3.4 A	Thermostat	68	10 A
25/4 B4	3-phase	230 / 400	50	2.70	2.04	25	1376	7.9 / 4.6 A	Thermostat	68	10 A
35/4 B4	3-phase	230 / 400	50	3.50	2.65	25	1424	12.0 / 6.9 A	Thermostat	68	10 A

## DIMENSIONS

Type	Discharge branch PN6/10	Cable quality (plug in)	Cable length	Weight approx.	Maximum solids
10/2 A1	DN 65	H07RN-F-6G 1.5	10 m	41 kg	40 mm
15/2 A1	DN 65	H07RN-F-6G 1.5	10 m	42 kg	40 mm
25/2 A2	DN 65	H07RN-F-6G 1.5	10 m	48 kg	40 mm
35/2 A2	DN 65	H07RN-F-6G 1.5	10 m	52 kg	40 mm
25/2 B1	DN 80	H07RN-F-6G 1.5	10 m	45 kg	70 mm
35/2 B2	DN 80	H07RN-F-6G 1.5	10 m	55 kg	70 mm
10/4 B1	DN 80	H07RN-F-6G 1.5	10 m	45 kg	70 mm
15/4 B3	DN 80	H07RN-F-6G 1.5	10 m	50 kg	70 mm
25/4 B4	DN 80	H07RN-F-6G 1.5	10 m	59 kg	70 mm
35/4 B4	DN 80	H07RN-F-6G 1.5	10 m	62 kg	70 mm

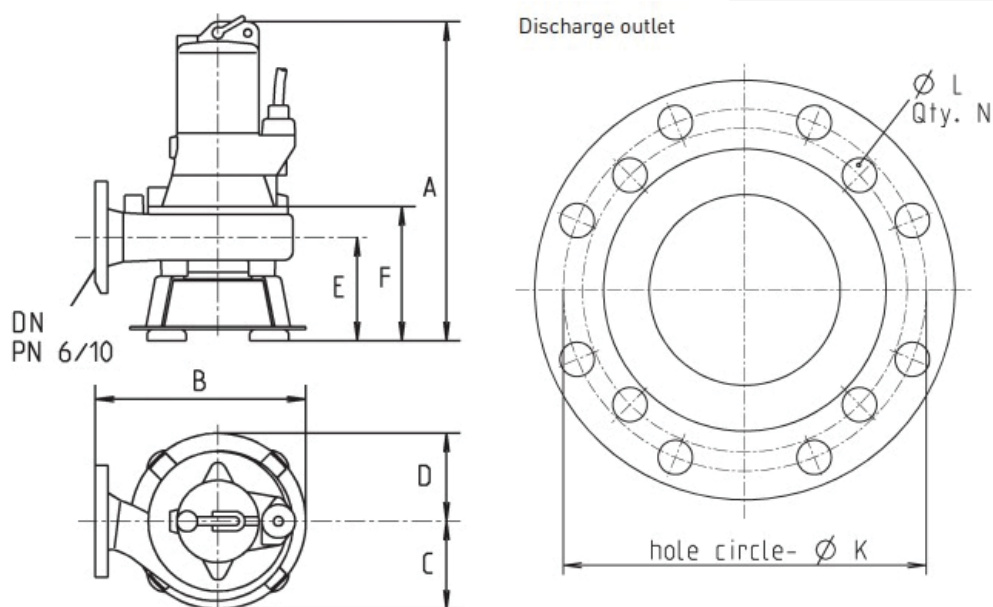

Type	A	B	C	D	E	F	K	L	N
10/2 A1	475	325	110	105	135	175	130 / 145	14 / 18	4
15/2 A1	475	325	110	105	135	175	130 / 145	14 / 18	4
25/2 A2	475	345	135	135	135	185	130 / 145	14 / 18	4
35/2 A2	510	345	135	135	135	185	130 / 145	14 / 18	4
25/2 B1	530	340	135	135	185	240	150 / 160	18	4 / 8
35/2 B2	570	380	145	135	185	240	150 / 160	18	4 / 8
10/4 B1	530	340	135	135	185	240	150 / 160	18	4 / 8
15/4 B3	535	380	160	160	185	240	150 / 160	18	4 / 8
25/4 B4	535	440	190	160	185	240	150 / 160	18	4 / 8
35/4 B4	570	440	190	160	185	240	150 / 160	18	4 / 8

**PERFORMANCE**

Type	P/No	Delivery head [m]	1	3	6	9	12	15	18	20	22	24
10/2 A1	JP09615	Flow rate [lpm]	633	533	367	200						
15/2 A1	JP09616		833	767	617	467	300					
25/2 A2	JP09617		1033	967	850	700	550	383	217			
35/2 A2	JP09651		1167	1117	1050	933	800	667	500	400	267	167
25/2 B1	JP09618		1517	1333	1033	717	350					
35/2 B2	JP09652		2100	1950	1617	1217	817	383				
10/4 B1	JP09620		1000	667	50							
15/4 B3	JP09622		1633	1317	750	200						
25/4 B4	JP09623		2000	1767	1283	717						
35/4 B4	JP09647		2200	1983	1583	1067	500					

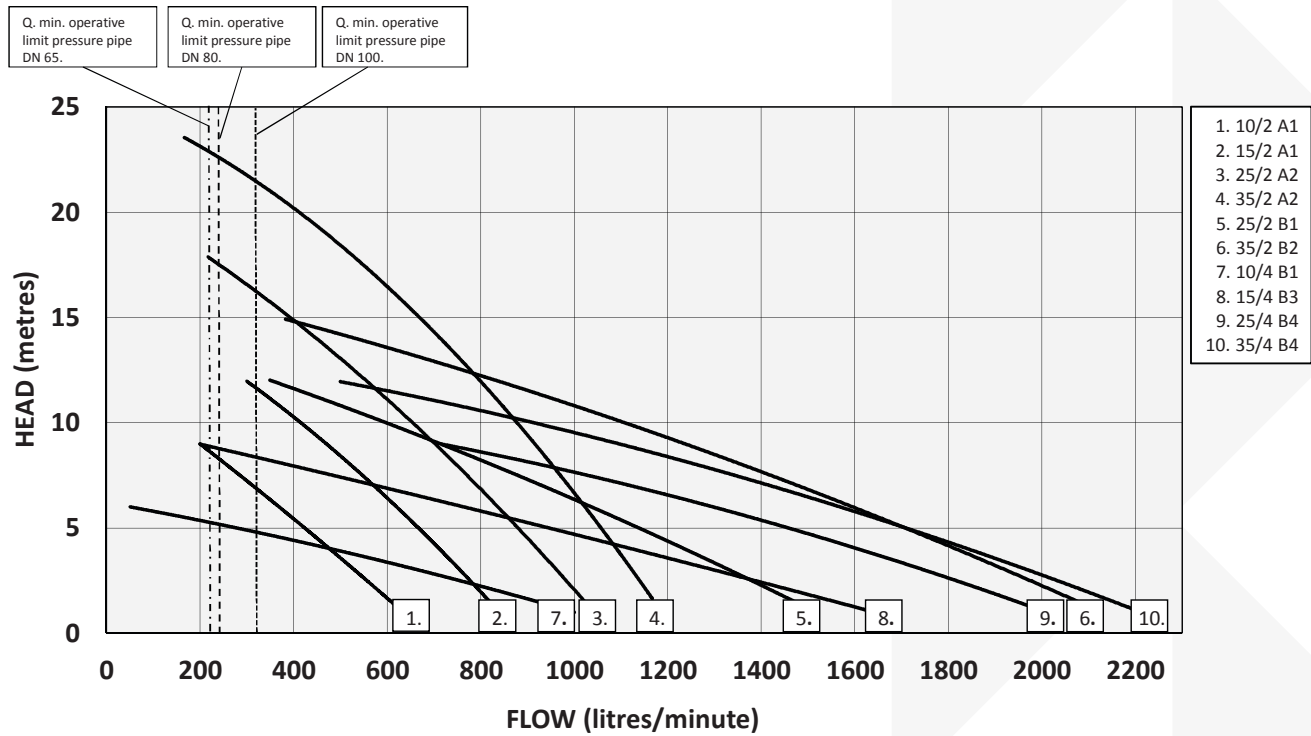

Head Office Pentair AU/NZ: 1-21 Monash Drive, Dandenong South, VIC 3175, Australia. [www.pentair.com.au](http://www.pentair.com.au)

All Pentair trademarks and logos are owned by Pentair, Ltd. All other brand or product names are trademarks or registered marks of their respective owners. Because we are continuously improving our products and services, Pentair reserves the right to change specifications without prior notice.

Pentair is an equal opportunity employer.  
 ABN 27 004 856 204 © 2012 Pentair, Ltd. All Rights Reserved.

© 2015 Pentair

L100347 1015