

**GP960**  
ENGINE DRIVE PUMPS  
CENTRIFUGAL 3" WATER TRANSFER PUMPS



GP960



**FEATURES**

Aluminium casing for lightweight high grade corrosion resistance.

Cast iron open style impeller.

3" inlet and outlet for high flow rates.

Strong and durable construction.

Rotatable discharge port makes the unit adaptable to various applications.

Built-in non-return valve aids quick priming.

Max. head - 26 m.

Max. flow - 975 lpm.

**APPLICATIONS**

- High flow water transfer.
- Flood water evacuation.

**PUMP INFORMATION**

Horizontal, single-stage, surface mounted centrifugal pump with cast iron open style impeller for pumping debris free water coupled to a Honda GX200 or a Briggs & Stratton 6HP (Intek I/C 6.0) engine.

**OPERATING CONDITIONS**

Suitable for pumping clean non-aggressive liquids without solids or fibres in suspension.

Fluid: Water.  
Maximum water temperature: 40°C.  
Minimum water temperature: 1°C.  
Maximum ambient temperature: 40°C.\*

\*Engine performance greatly reduced with increased ambient temperature and/or altitude, clarify with Engine Manufacturer.

## ENGINE DATA

Type	Engine	Model	Nominal HP	Displacement CC	Continuous duty	Fuel tank capacity	Fuel	Fuel consumption @ 3600 RPM	Recommended oil type	Oil capacity
GP960	Honda	GC200	-	196	3000 RPM	3.1 litres	Unleaded	1.7 litres/hour	10W/30 API SG	0.6 litres
GP960	B&S	Intek I/C	6	205	3000 RPM	3 litres	Unleaded	2.11 litres/hour	SAE30	0.6 litres

## DIMENSIONS

Type	Weight approx.	Inlet	Outlets	Carton L x W x H	Packed weight
GP960 H	27.7 kg	3" BSP (male)	3" BSP (male)	530 x 420 x 530 mm	28 kg
GP960 B&S	28.6 kg	3" BSP (male)	3" BSP (male)	620 x 460 x 560 mm	29 kg

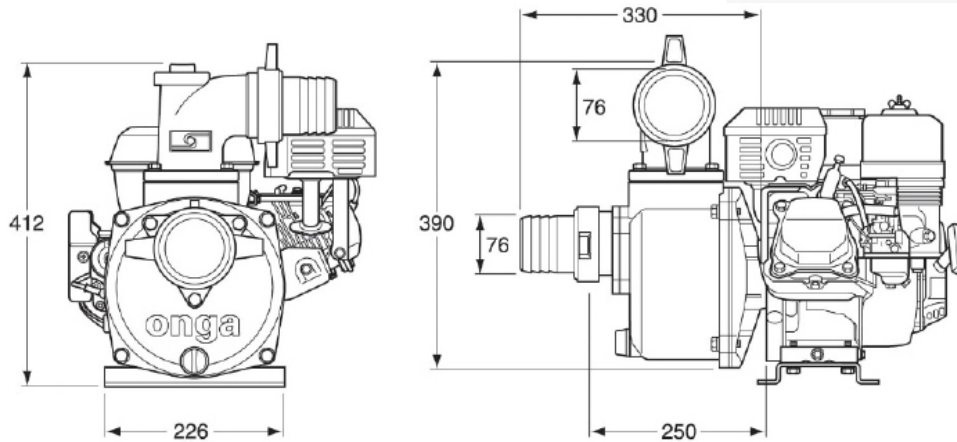

## PERFORMANCE

Type	P/No	Delivery head H [m]	5	10	15	20	25
GP960 H	333314	Capacity [litres per minute]	-	943	764	510	70
GP960 B&S	333315						

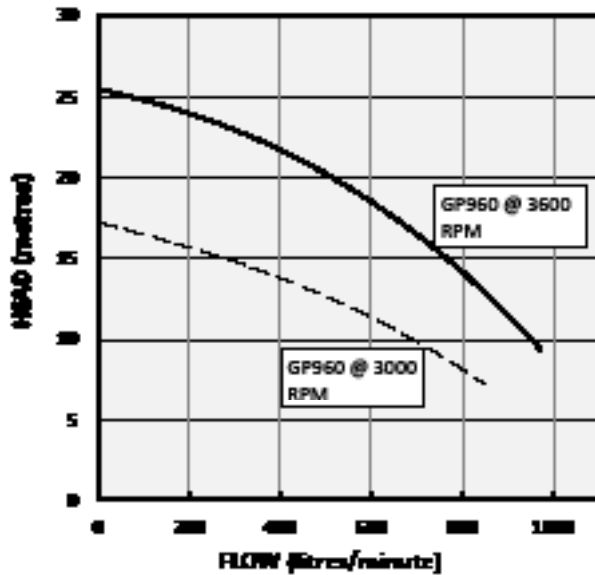

## NPSHR

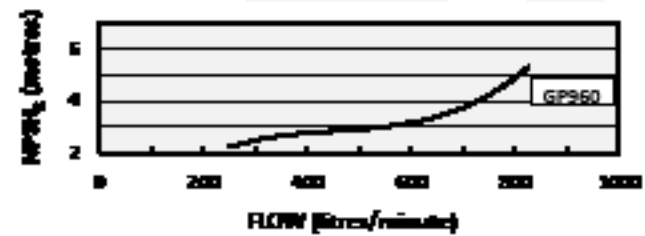

## PUMP CONSTRUCTION MATERIALS

Component	Material
Pump casing	Powder coated aluminium
Impeller	Cast iron
Diffuser	Cast iron
Nuts & tails	Polypropylene
Seal flexible bellows	Nitrile
Seal stationary face	Ceramic
Seal rotating face	Carbon
Seal spring	Stainless steel
Motor shaft	Mild steel
O'Rings	Nitrile



Head Office Pentair AU/NZ: 1-21 Monash Drive, Dandenong South, VIC 3175, Australia. [www.pentair.com.au](http://www.pentair.com.au)

All Pentair trademarks and logos are owned by Pentair, Ltd. All other brand or product names are trademarks or registered marks of their respective owners. Because we are continuously improving our products and services, Pentair reserves the right to change specifications without prior notice. Pentair is an equal opportunity employer.

ABN 27 004 856 204 © 2012 Pentair, Ltd. All Rights Reserved.

© 2015 Pentair

L100275 0815