



ONGA[®]

SMH RANGE

HORIZONTAL MULTISTAGE CENTRIFUGAL PUMPS

SMH35 SMH45 SMH55 SMH75 SMH90



We recommend, for additional protection, the pump to be supplied from socket outlet protected by a residual current device - RCD (also known as an earth leakage circuit breaker - ELCB) with a maximum rated residual current of 30mA.

Should the installer or owner be unfamiliar with the correct installation or operation of this type of equipment, contact the distributor or manufacturer for correct advice before proceeding with installation or operation of the product

Relax - you've bought an **ongga**...

Congratulations on your decision to purchase an Onga product. Onga is one of the best know brands in its fi eld, with a proud local and international reputation.

Onga is a brand for reliability, value for money and technological innovation. You will fi nd Onga product wherever people need to move water in 3 broad markets covering:



Residential

Technologically advanced solutions for moving and treating water in the Home, Garden, Pool and Spa.



Agricultural

Innovative Stock and Crop water management solutions for Primary Industries.



Process

Water movement products for Building services, Emergency services and Original Equipment Manufacturers.

1. Continual Product Improvement

We employ the best engineers both in Australia and around the world to develop new and better ways to take water further.

2. Operational Excellence

There is only one standard that we set ourselves for both product quality and the quality of our service. That standard is excellence... to have no-one better than us at what we do... nothing short of that is acceptable. Our commitment to quality is reinforced with our ISO 9001:2000 accreditation.

3. A Fair Price

Onga products are neither the cheapest nor the most expensive in their field. Our products do, on the other hand, always represent very good value for money; they always have and they always will.

4. Our Team of Dealers

The hand picked authorised Onga dealer network throughout Australia and worldwide are second to none. We invest considerable time and resources training and supporting them through the Onga Training Academy.



Table of Contents

Page

Model Data	4
Application	5
Installation	6
Operation	11
Service and Maintenance	13
Trouble Shooting	14
Warranty	15

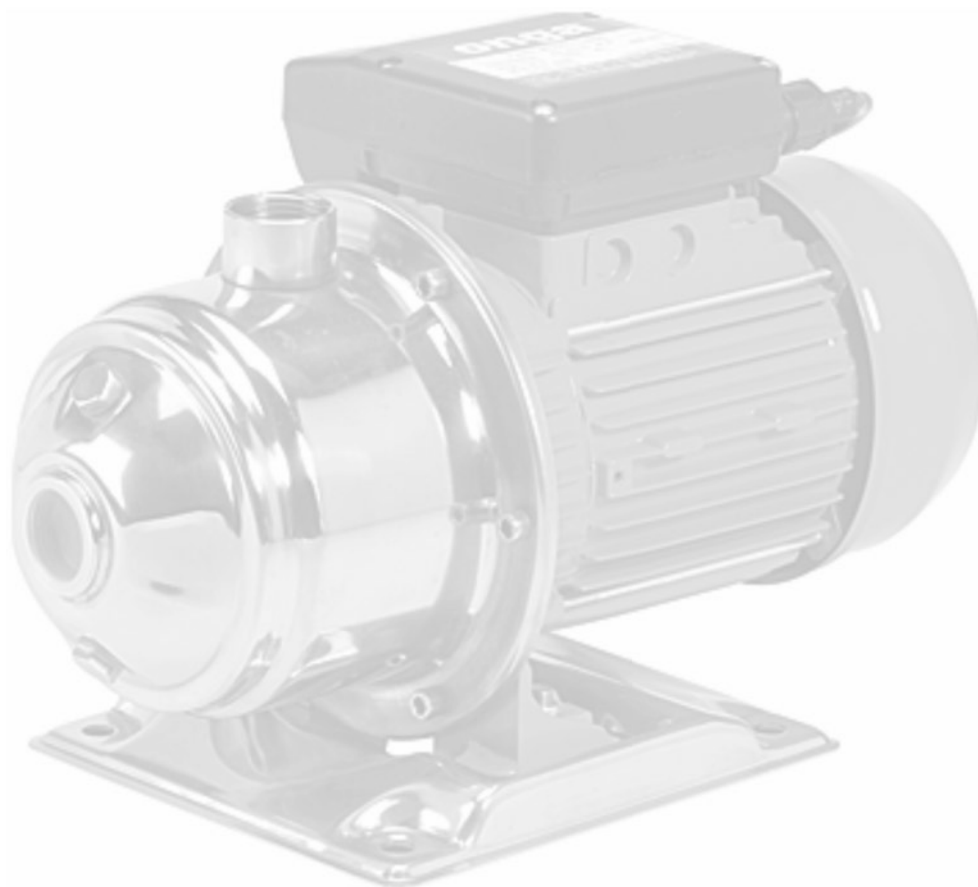

Model Data

Model	Motor
	(W)
SMH35	350
SMH45	450
SMH55	550
SMH75	750
SMH90	900

Technical Information

Inlet(Suction):	1" BSPF
Outlet(Discharge):	1" BSPF
Water Temperature Range:	1° - 50°C
IP Rating:	IP44
Electrical Supply:	230V +10%, -6%, 50Hz single phase
Maximum Ambient temperature:	55 °C

Application

Onga SMH Series pumps are suitable for pumping clean water in a domestic water system, small irrigation applications, and as pressure booster pumps. The strength of the stainless steel pump casing coupled with the impervious nature of the technopolymer impeller and diffuser make it ideally suited for most potable water pumping applications.

NOTE: Consult your Onga dealer for information regarding the suitability of each SMH pump in an automatic pressure system prior to installation.

Installation



The electrical installation shall be in accordance with the national wiring rules (AS/NZS 3000) for class 1, IP44 rated products.



These instructions are a guide only. Users not familiar with pumping equipment should seek advice from people experienced in pump equipment and installation.



Freezing conditions will damage the unit, because when water freezes it expands. Ensure that the pump is located so that it is not prone to freezing, or ensure that the product is disconnected and dried of water during cold conditions.



SMH pumps are electrically connected. Ensure that they are switched off and unplugged from socket outlet during installation and any subsequent service work.



The pump is designed to be used with clean water in a residential application. Do not use it with alternative fluids, abrasive, corrosive or explosive fluids. Do not install or operate your pump in an explosive environment or near combustible matter.



Incorrectly installed or tested equipment may fail, causing severe injury or property damage.



Fire and burn hazard. Modern motors run at high temperatures. To reduce risk of fire, do not allow leaves, debris, or foreign matter to collect around the pump motor. To avoid burns when handling the motor, let it cool for at least 20 minutes before trying to work on it. Automatic thermal overload cut-out protects the motor for heat damage during operation and it will restart without notice when the motor cools down.



The pump is not intended for use by young children or infirm persons without supervision. Young children should be supervised to ensure that they do not play with the pump.

Read the following instructions in this owner's manual when installing and operating equipment.

1. Preparation for Installation

Inspect your pump for shipping damage. Report any damage to your Onga stockist. Make sure the suction piping is free of air leaks and is laid so that there can be no airlocks.

Warranty of these pumps is void unless they are operated in accordance with this owner's manual.

2. Pump Protection

The pump should be protected from the weather, floods, chemicals, dust, vermin, insects etc. It is highly recommended that the pump be housed in a weather proof, well vented enclosure. If the pump is not adequately housed the warranty may be deemed void.

3. Pipe Installation

Pumps can be damaged if care is not taken when connecting pipes. Pipes should be supported so that the pump casing is not strained by the weight or misalignment.

We recommend the pump and pipe are coupled using flexible type polythene pipe, rubber hose or a multi-directional barrel union. This union coupling can also be used to remove the pump for service should it be necessary without having to cut pipes.

Pipe fittings should be carefully screwed onto the pump making sure not to cross-thread or overtighten. We recommend the use of a moulded pipe fitting to connect to the pump as this avoids possible damage to the pump threads and unnecessary replacement of parts.

For best results use teflon tape to join seal joint. Satisfactory sealing can be achieved by hand tightening fittings ensuring that no leaks are evident once under pumping pressure.

4. Locating the Pump

Find a location for your pump as close to your water source as possible. Ensure that this location is on a separate footing from your home. To do this you can mount the pump on a concrete tile or concrete base.

5. Power Source

Arrange for an electrician to install an outdoor 10A GPO electrical outlet near the pump if there is not one there already.

6. Suction

This is the most important part of the installation as errors will cause significant problems for the system in performance and longevity.

IMPORTANT: A gate valve must be installed at the tank outlets.

Installations where the tank base is below the pump

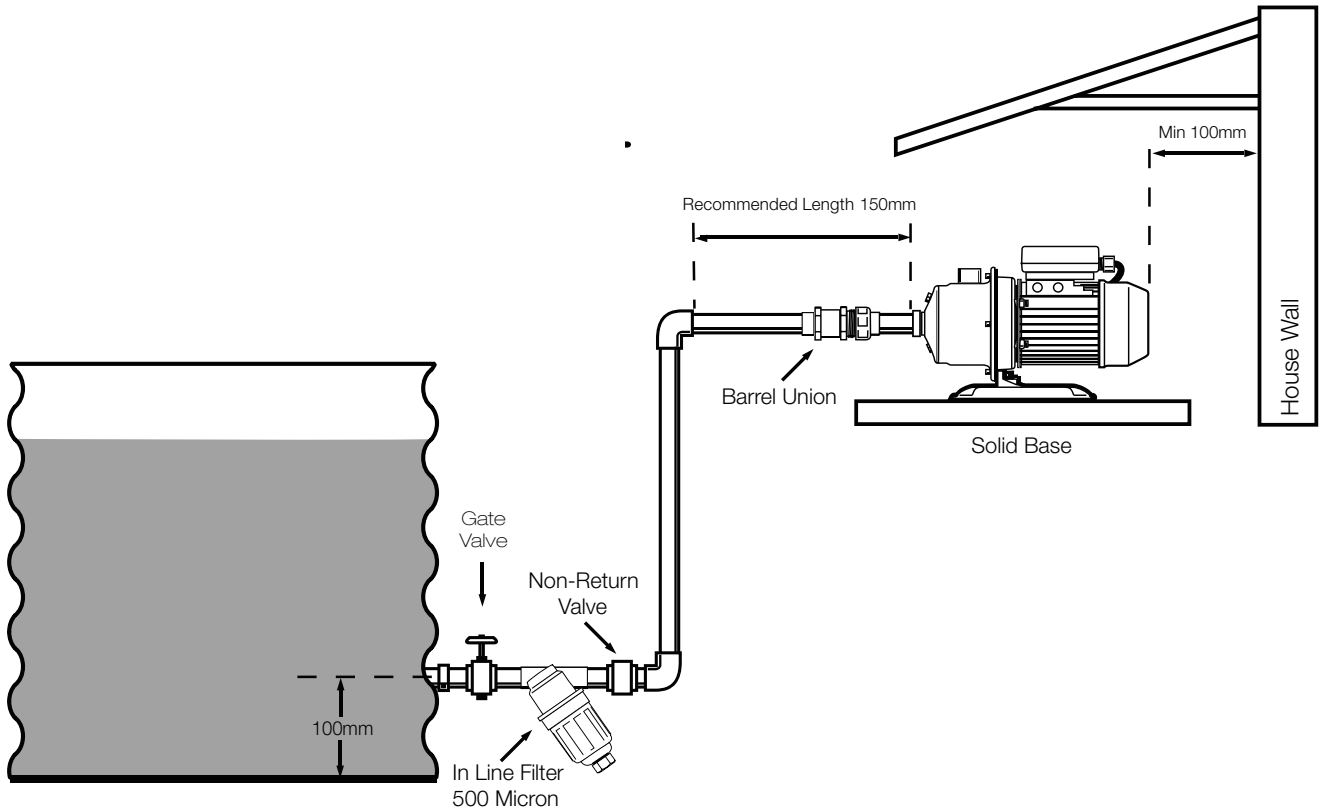

Installations where the tank base is level with the pump

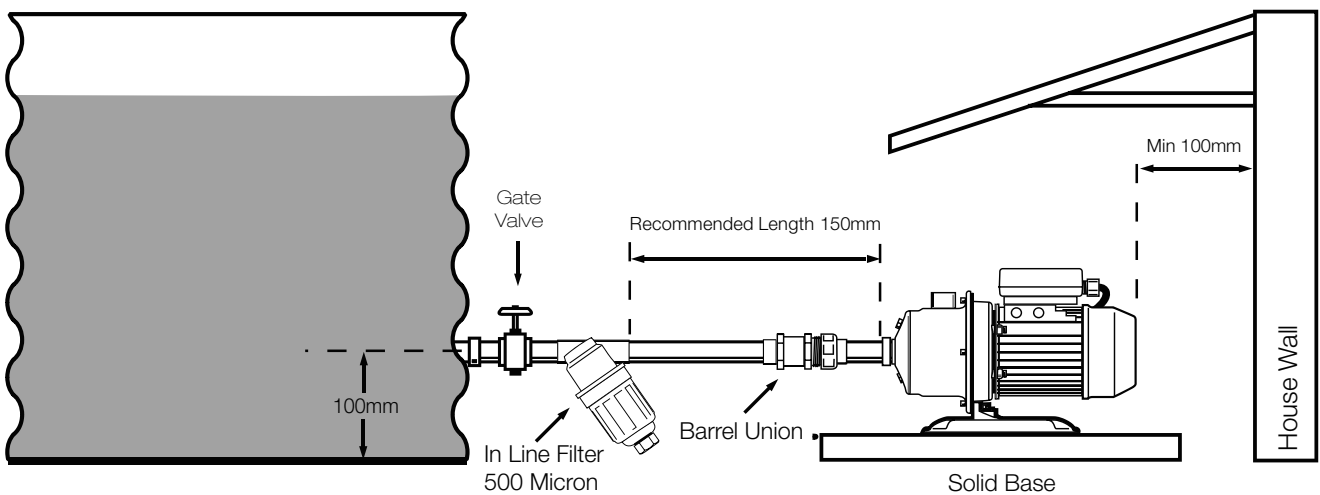

To maintain optimum performance from your pump, the suction pipe should be:

- Kept to the shortest distance practical, but not shorter than therecommendedlength.
- Re-enforced crush resistant (non-collapsible) hose or pipe.
- All fittings should be air tight.
- Pipes should be equal to or larger than the diameter of the suction/inletport.
- Ensure that the suction is completely submerged.

In-line strainers/filters are only recommended for pumps fitted with Minipress, PressControl or WaterSwitch. Regular maintenance is required to keep them clean and provide maximum pump pressure.

Consult your Onga dealer for information regarding the suitability of each SMH pump in an automatic pressure system prior to installation.

7. Discharge

The length and diameter of the discharge hoses/pipes will affect the pressure and flow rate at which your pump operates. Pressure ratings of all components must exceed the maximum pressure of the pump by an appropriate safety factor. All pipework should be supported independently of the pump.

8. Pump Priming

Ensure that there is at least 200mm of water in your tank, (i.e. that the tank outlet is covered, and the pump will not draw any air into the system). Open the gate valve on the tank. Check for any leaks, and repair these if necessary.

If no leaks are present, remove the priming plug to open the priming port on the top of the pump case.

If the tank is above the level of the pump, water will start to run out of this port. Replace the priming plug carefully. Your pump is now ready to run. (Note: If a check valve is installed in the suction line, water may not fill the pump. If this occurs, follow the instructions below).

If the tank water level is below the level of the pump, you will need to fill the pump body and suction line. Remove the priming plug and fill the pump body and suction line using a funnel.

9. Electrical

The pump is supplied with a interconnection appliance coupler and standard Australian 10 Ampere plug and cord. Connection to the power supply is a

matter of inserting the plug into the suitable socket outlet. Before plugging the power supply cord into the socket outlet, connect the pump to it using the provided IEC appliance connectors on the end of the interconnection cords. Ensuring there are no water traces on the connectors push them firmly into each other to ensure intended splash (water) proof protection. This connection shall be separated again only for service purpose and only after the power supply is removed by unplugging the cord from the socket outlet. The socket outlet shall be in a dry and flood free location; preferably do not use extension cords for this very reason and because they can cause voltage drop.



Supply voltage outside limits specified in Model Data can cause motor overheat leading to overload tripping, reduced component life or seriously damage pump and voids warranty.

We recommend, for additional protection, the pump to be supplied from socket outlet protected by a residual current device – RCD (also known as an Earth Leakage Circuit breaker – ELCB) with a maximum rated residual current of 30mA.

Operation



The pump operator or owner must be provided with this owner's manual. This must be read before operation, and followed during operation.



Ensure that your pump is filled with water before operating.



The pump is designed to be used with clean water in a residential application. Do not use it with alternative fluids, specifically abrasive, corrosive or explosive fluids. Do not install or operate your pump in an explosive environment or near combustible matter.



Fire and burn hazard. Modern motors run at high temperatures. To reduce risk of fire, do not allow leaves, debris, or foreign matter to collect around the pump motor. To avoid burns when handling the motor, let it cool for at least 20 minutes before trying to work on it. Automatic thermal overload cut-out protects the motor for heat damage during operation and it will restart without notice when the motor cools down.

1. Start-up / Operation

Ensure you have primed the pump correctly. (Instructions on priming the pump can be found in the installation section under Point 8. Priming Pump).

Note: If the pump is not used for a long period of time, repeat the priming procedure before start up.

Start the pump and check rotation of the motor. It rotates in a clockwise direction when viewing the fan through the cowl behind the motor.

2. D.R.O.P (Dry Running Over-Temperature Protection)

The Onga SMH series of pumps (excluding the SMH35) are fitted with the internationally patented D.R.O.P system which protects the hydraulic parts from possible damage that can be caused by overheating of the liquid inside the pump casing.

The overheating can be the result of external causes (outside the pump) or occurs because the pump stops priming and as water is pumped out the pump runs dry.

The D.R.O.P system is reset using the switch located on the condenser box.

3. Restoring Operation

Set the switch to “0”, unplug unit from power outlet. Remove cause of malfunction.

Wait a few minutes, allowing all the hydraulic parts to cool down.

Set the switch on the “1”, plug the unit into power outlet. The red light goes off and the pump starts operating. If the red light remains on, turn the switch to “0”, unplug the unit, wait a few minutes and repeat the start up procedures.

Service and Maintenance



Pump should only be serviced only by qualified personel. For best results, use only genuine service parts. Be sure to prime pump before starting.



To avoid dangerous or fatal electrical shock, turn OFF power to pump and remove plug from outlet before attending the pump.



RCD tripping indicates an electrical problem. If RCD trips and will not reset have a qualifi ed electrician inspect and repair electrical system and/or pump.



If service is required to the power supply cord and/or appliance connectors, they must be replaced with the specialised cord assemblies by Pentair Water service agent or similarly qualified personnel in order to avoid a hazard.



Liquid may be HOT, release pressure with care before servicing.

1. General Care and Maintenance

Under normal conditions the Onga SMH series of pumps requires only minimal attention.

In order to prevent possible failures, it is advisable to periodically check the pressure supplied and power absorption. A decrease in pressure is a symptom of wear. An increase current absorption is a sign of abnormal mechanical function in the pump and/or motor.

Troubleshooting

Symptom	Cause	Remedy
Pump does not operate and motor does not run.	No Electricity	Verify presence of electricity.
	Not Plugged in correctly	Ensure pump is connected properly
	Circuit breaker activated	Reset circuit breaker
Pump hums and the thermal relays cut in and out	Pump is clogged by debris	Clean suction pipe and foot valve/strainer. Clean the pump by flushing with water. Remove the priming and drain plugs. If the pump cannot start after several flushings, it must be dismantled and cleaned.
	Capacitor is defective	Replace Capacitor
Pump operates but delivers no water.	Pump is not filled with water.	Fill the pump with water (see installation section - Priming Pump)
	Suction head is too high	Reduce the suction head
	Foot valve/strainer is not submerged enough	Make the suction pipe longer (max 8 metres)
	Suction pipe is taking in air	Check the suction pipe and joints for air leaks.
	Suction pipe/strainer or non-return valves are clogged with debris	Clean the suction pipe/strainer or non-return valve
	Pump is clogged with debris	Clean the pump of debris
Reduced performance	Suction head is too high	Reduce suction head.
	Foot valve/strainer only partially submerged	Lengthen suction pipe.
	Pump shaft seal is worn or damaged	Replace defective parts
	Pump is partially blocked with debris	Remove debris and flush pump with clean water
	Pressure switch setting are incorrectly set or faulty.	Check and adjust pressure switch and/or replace faulty parts.

Should problems persist, contact your nearest Onga Service Agent.

IMPORTANT

Please attach your sales invoice/docket here as proof of purchase should warranty service be required.

Please do not return Warranty - Retain for your records.

Purchased From

Purchase Date..... Serial No..... Model No.....



1-21 Monash Drive,
Dandenong South, Vic 3175

Australia

National Customer Service: Phone: 1300 137 344
Fax: 1800 006 688
National Dealer Locator: Phone: 1800 664 266
Email: au.sales@pentair.com
Web: www.pentair.com.au

New Zealand

National Customer Service: Phone: 0800 654 112
Fax: 0800 806 642
National Dealer Locator: Phone: 0800 664 269
Email: nz.sales@pentair.com
Web: www.pentair.co.nz

International Australia/New Zealand

Phone: +61 3 9709 5800
Fax: +61 3 9709 5888

© Information contained here-in remains the property of Pentair Pty Ltd. Any reproduction, display, publication, modification or distribution is strictly prohibited without the prior written permission of Pentair Pty Ltd.

Disclaimer: Pentair reserves the right to change product specifications and products details. All product images are for reference purposes only and may not represent actual and/or current product.