

Installation and Operating Instructions



SBI(N)-Series

VERTICAL MULTI-STAGE
CENTRIFUGAL PUMPS



Models 1, 3, 5, 10, 15, 20, 32, 45, 64, 90



1. Model numbering and nameplate format

1.1 Model numbering

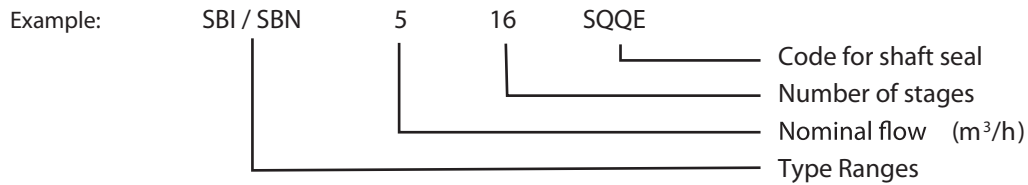

1.2 Nameplate format

1. Pump Type - Seal Type
2. Pump Model
3. Frequency
4. Rated Power
5. Speed
6. Maximum Head
7. Capacity
8. Head Range
9. Maximum Operating Pressure
10. Direction of Rotating
11. Serial number

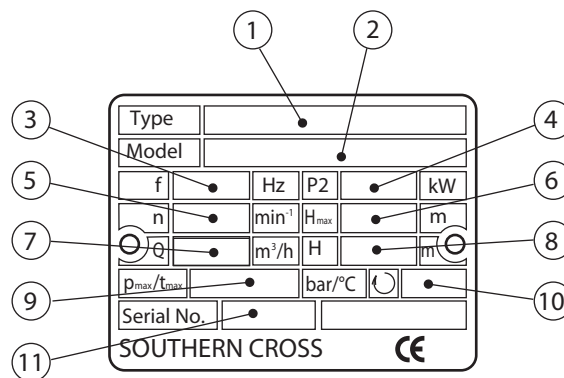

2. Handling

Read these instructions carefully before beginning installation. Lift and handle these pumps carefully. SBI & SBN series are vertical multi-stage non-self priming pumps coupled with standard electric motors. This manual applies to standard version pumps and for standard applications. Contact your Southern Cross Dealer for information about special pump versions and applications.

3. Applications

SBI and SBN series in-line pumps booster pumps are designed for a wide range of applications in various industries – for water treatment, water boosting, water supply, cooling, cleaning, etc.

3.1 Pumped liquids

These pumps are designed for use with clean, non-viscous and non-explosive liquids that do not contain abrasive matter.

WARNING: These pumps are not designed to be used with abrasive, solid containing, explosive and corrosive liquids. For special application, please contact your supplier or Southern Cross.

4. Technical data

4.1 Temperatures

Ambient temperature: 0°C to +40°C

WARNING: If ambient temperatures are above +40 degrees C, or if the pump is located at elevations more than 1,000 meters above sea level, the motor's output must be decreased to compensate for less effective cooling, and may have to be replaced with a larger motor.

Liquid temperature: -15°C to +120°C

4.2 Maximum operating pressure

Refer to page 7

4.3 Minimum inlet pressure-NPSH

To avoid cavitation, make sure that there is a minimum pressure on the suction side of the pump.

NPSH_A: Net Positive Suction Head Available

— The net positive suction head available is a function of the pump suction system.

NPSH_R: Net Positive Suction Head Required

— The net positive suction head required is a function of the pump design at the operating point on the pump performance curve.

$NPSH_A = H_a - H_s - H_f - H_v - H_{st}$ (in meters head)

H_a: Barometric pressure. (That can be set to 10.2 m.)

H_s: Suction lift.

H_f: Friction loss in suction pipe.

$H_v = K_T + K_H$: Vapor pressure

K_T: Pressure reduction due to liquid temperature.

K_H: Pressure reduction due to elevation above sea level.

If the liquid is water, refer to the table below to determine the values of K_T and K_H.

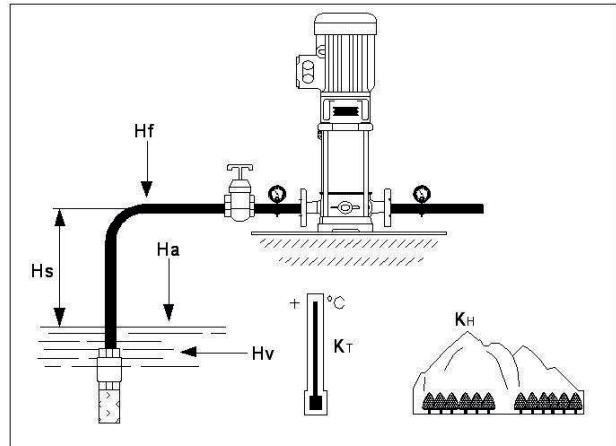

T (°C)	20	30	40	50	60	70	80	90	100	110	120
K _T (m)	0.2	0.4	0.8	1.3	2.2	3.3	5	7.4	11	15	22
H (m)	0	500	1,000	1,500	2,000	2,500	3,000				
K _H (m)	0	0.55	1.1	1.65	2.2	2.75	3.3				

H_{st}: Safety margin. (minimum: 0.5 meters head)

NPSH_A > NPSH_R: Pump running will be fine.

NPSH_A < NPSH_R: The pump will be dry running or cavitating.

WARNING: Stop operation of the pump if cavitation occurs. Cavitation will cause pump damage and the resultant damage is not subject to warranty

4.4 Minimum nominal flow rate

To prevent overheating of the internal pump components, the pump should not be used at flows below the minimum flow rate.

WARNING: Do not run the pump against a closed discharge valve for longer than a few seconds.

The curve below shows the minimum flow rate required as a percentage of the pump nominal flow rate in relation to the liquid temperature.

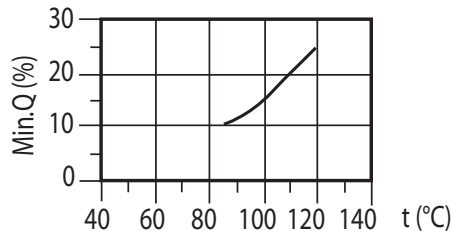

4.6 Electrical data

See the motor nameplate.

WARNING: Make sure that the supply voltages, phase and frequencies correspond to the motor specifications.

4.7 Number of starts per hour

Motors up to and including 4 kW: Maximum 100 starts per hour.

Motors of 5.5 kW and up: Maximum 40 starts per hour.

WARNING: If you use another brand of motor then check the manufacturer's instructions for the maximum frequency of starts.

5. Installation

Always refer to the local or national regulations and codes relating to the selection of the installation site, the water and power connections, etc.

5.1 Position

Pumps should be installed in a protected environment – not exposed to weather. Make sure that there are no obstructions to prevent proper motor cooling.

5.2 Anchoring

The pump must be secured to a solid foundation by bolts through the holes in the flange or base plate.

An illustration of page 7 shows the bolt location and the pipe connections.

5.3 Installation example

When positioning and installing the pump, follow the installation examples below in order to avoid damaging the pump.

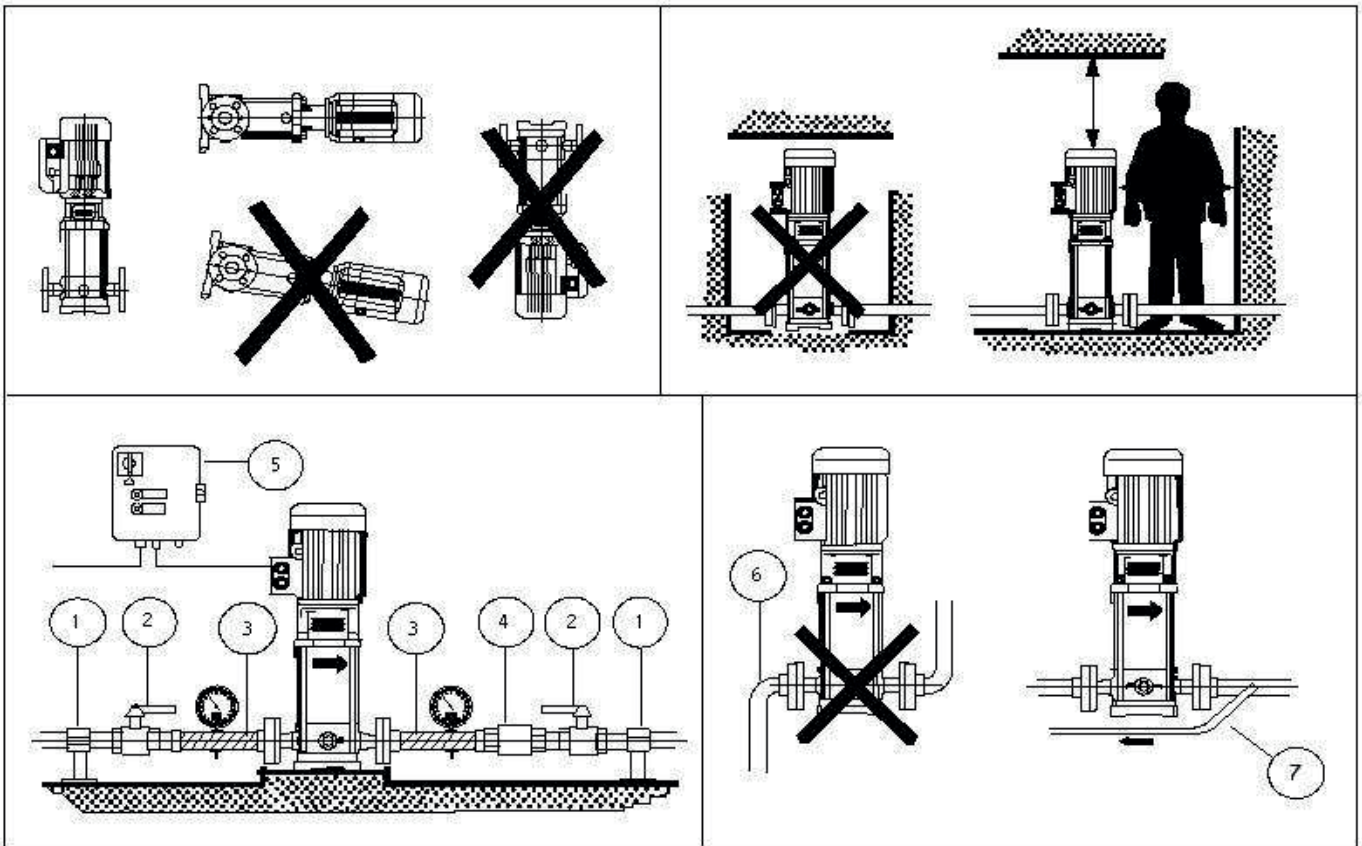

Pos.

Description

1. Pipe support: Support piping system properly to avoid stresses on connections.
2. On-off valves: Install on-off valves for easy access- before the pump intake and after the pump discharge.
3. Use flexible piping on both inlet and outlet sides of the pump to reduce vibration and transmission of noise.
4. Check valves will prevent return flow of pumped liquid when pump is stopped, reducing the danger of pump damage.
5. Control Panel: Use high quality components. Make sure that the panel conforms to local standards and regulations.
6. Do not place elbows next to the pump inlet and discharge.
7. If pump needs to be operated with on-off valve closed, install a by-pass line to avoid damaging the pumping system.

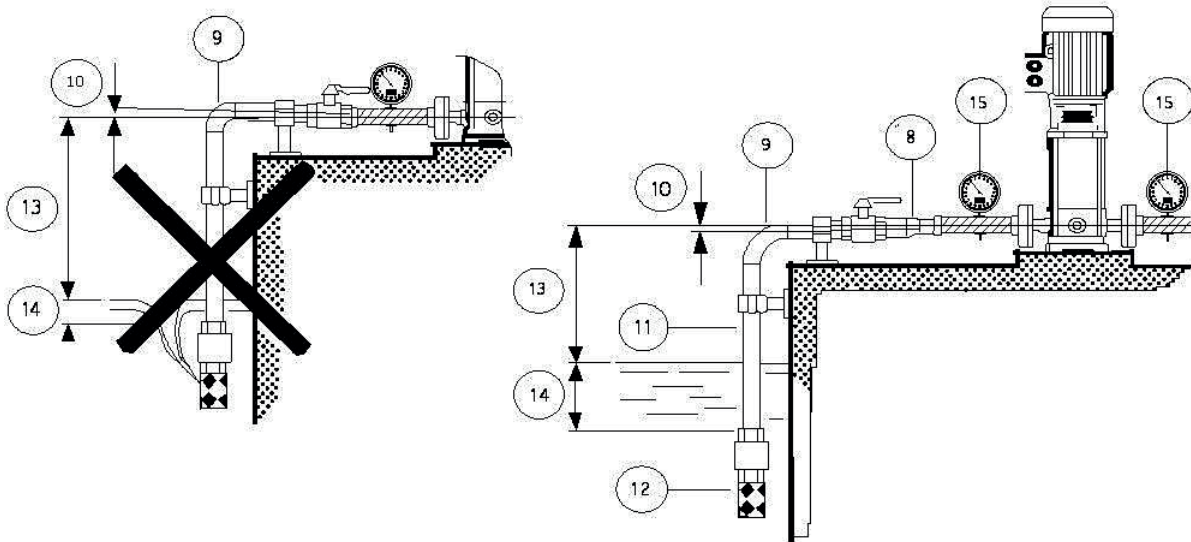

8. If it is necessary to increase the diameter of the suction pipe, place an eccentric reducer between the check valve and the flexible pipe section.
9. Using elbows will increase the flow resistance. Long radius bends will result in less flow resistance.
10. The piping must have a level or positive gradient to prevent the formation of air pockets.
11. The diameter of the drop pipe must be bigger than the diameter of the pump's suction port.
12. Use a foot valve in case of negative suction head.
13. Size pump for correct head.
14. Place the intake of the suction pipe so that the footvalve is always submerged to prevent entry of air.
15. Install a compound gauge at the pump suction and a pressure gauge at the pump discharge.

6. Electrical connection

- All electrical connection should be in accordance with the local regulations and made by a qualified electrician.
- Make sure that the supply voltages and frequencies, and phase are suitable for the motor used.
- Before proceeding, make sure that all the connections are grounded and well insulated.
- Overload protection should be provided.
- To connect, proceed as shown on the inside of the terminal board cover.
- The terminal box can be turned to four positions.
- Check the direction of rotation (Three-phase motor only).
- Make sure that the controls are properly grounded.
- To avoid the possibility of dry running, we strongly recommend installing dry running protection.

7. Start-up

The pump and suction pipe should be filled with the liquid to be pumped before start-up to prevent dry running at start-up.

WARNING: Dry running can damage the pump bearing and shaft seal.

7.1 Operation

- Start the pump and check the direction of rotation of the motor (Three-Phase motors).
- Start the pump, keeping the on-off valve of the discharge side of the pump closed. Then, open the on-off valve slowly. The pump must run smoothly and noiselessly. If not, then it may be necessary re-prime the pump.
- Check the current drawn by the motor. If necessary, adjust the setting of the thermal relay.
- Any air pockets trapped inside the pump may be released by adjusting the air screw.

WARNING: If the pump is installed in a location where it is subject to freezing when not in operation, then the pump should be drained to prevent damage from freezing.

and the pipe system

7.2 Others (Only for SBI, SBN 1, 3, 5 series)

- For these pumps, it is advisable to open the bypass valve during start-up. The bypass valve connects the suction and discharge sides of the pump, thus making the filling procedure easier. When the operation is stable, the bypass valve can be closed.
- If the pumped liquids contains air, it is advisable to leave the bypass valve open if the operating pressure is lower than 6 kg/cm². If the operating pressure constantly exceeds 6 kg/cm² the bypass valve must be closed. Otherwise the material at the opening will be worn because of the high liquid velocity.

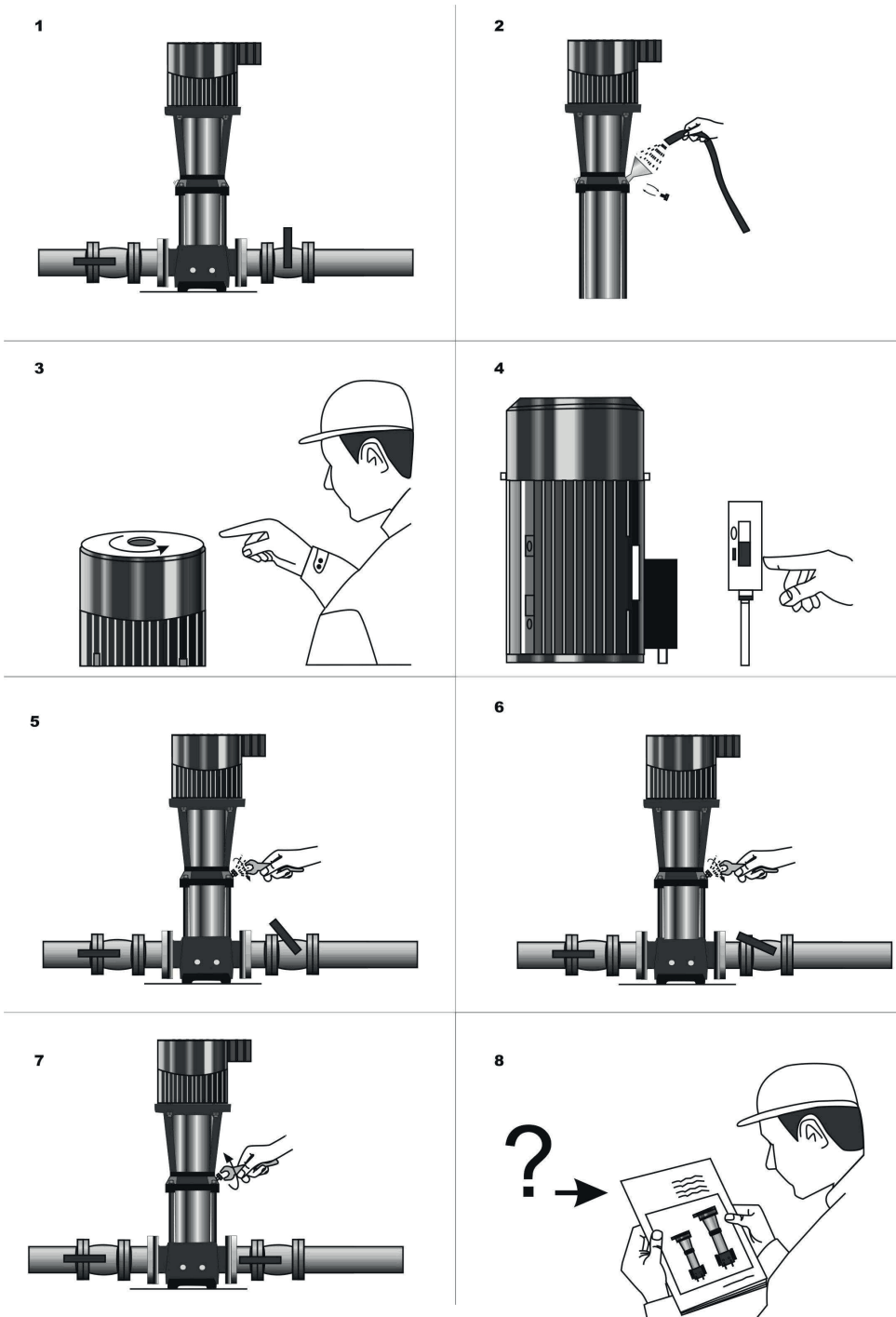
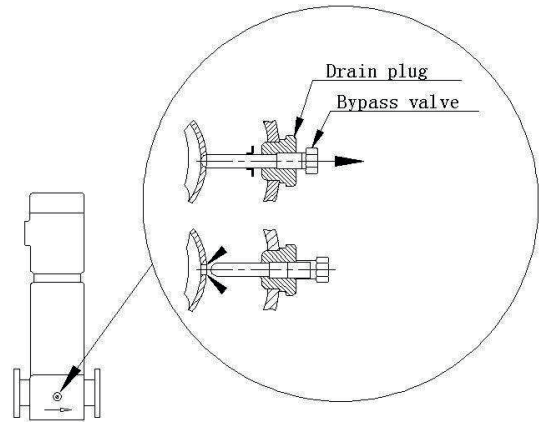

8. Maintenance

WARNING: Before starting maintenance work on the pump, the motor, or other parts of the system, make sure that the power supply has been switched off.

- The pump does not have a recommended maintenance schedule.
- If the motor is fitted with grease nipples, then the motor should be lubricated with a high temperature lithium-based grease. If not, then the motor does not require regular maintenance.
- If the pump and motor are used infrequently with long intervals of non-operation, then we recommend that the motor be greased.
- Coupling adjustment: Refer to page 8 and 9.

9. Troubleshooting

Fault	Probable cause	Possible Solution
Pump does not run when the motor starter is activated.	<ul style="list-style-type: none"> a. Supply failure or no power supply. b. Main contacts in motor starter are not making contact or the motor coils are defective c. Pump or auxiliary circuits protection fuses blown. d. Pump or piping system may be obstructed causing a jam. e. Motor may have failed. f. Motor protector or thermal relay has tripped out. g. Tripping of dry running protection. 	<p>Check connections or restart the power supply. Reconnect or replace contacts or magnetic coil.</p> <p>Replace fuses.</p> <p>Clean the obstruction and restart pump.</p> <p>Replace the motor.</p> <p>Reset the motor or thermal protector.</p> <p>Check the water level in the tank or the water system pressure. If everything is in order, check the protection device and its connection cables.</p>
Starter overload trips immediately when the power is switched on.	<ul style="list-style-type: none"> a. Overload setting is too low. b. The cable connection is loose or faulty. c. One fuse is blown. d. Pump is jammed by an obstruction e. Contacts in overload are faulty. f. The motor winding is defective. g. Low voltage (Especially at peak time). 	<p>Set the motor starter correctly.</p> <p>Fasten or replace the cable connection.</p> <p>Replace fuse and try starting again.</p> <p>Check and clean obstruction from system.</p> <p>Replace motor starter contacts.</p> <p>Replace the motor.</p> <p>Check the power supply.</p>
The pump starts but, after a short time, the thermal protector trips out or the fuses blow.	<ul style="list-style-type: none"> a. The voltage is not within the motor's operating limits. b. The control panel is situated in an excessively heated area or is exposed to direct sunlight c. A phase in the power supply is missing. 	<p>Check the operating conditions of the pump.</p> <p>Protect the control panel from heat sources and from the sun.</p> <p>Check the power supply.</p>
The pump starts but, after a period of time, the thermal protector trips	<ul style="list-style-type: none"> a. Worn motor bearings causing motor to overheat. b. The Pump's delivery rate is higher than the specified rate on the pump nameplate. c. There are obstructions inside the pump or pumping system. d. More viscous liquids may cause the pump to overload the motor, causing the motor to overheat. 	<p>Replace motor bearings.</p> <p>Partially close the on-off valve on the discharge side of the pump until the delivery rate is within the specified limits.</p> <p>Disassemble and clean the pump and piping.</p> <p>Check the actual power requirements based on the characteristics of the liquid being pumped, replace the motor accordingly.</p>
Pump runs but no water is delivered	<ul style="list-style-type: none"> a. Pump is not primed with liquid. b. The pump, suction or discharge pipes are blocked by solids in the liquid being pumped. c. The foot or check valve is blocked or has failed. d. The suction pipe leaks. e. Air in the suction pipe or pump. f. Motor operating in wrong direction (three-phase motor). 	<p>Fill the pump with the liquid to be pumped.</p> <p>Clean the pump, suction or discharge pipe.</p> <p>Replace the foot or check valve.</p> <p>Repair or replace the suction pipe.</p> <p>Remove trapped air from system..</p> <p>Change the direction of rotation of the motor by reversing motor connections.</p>
The pump capacity is not constant.	<ul style="list-style-type: none"> a. The pump draws in air or the inlet pressure is too low. b. The pump or the suction side of the piping system partly blocked by foreign bodies. 	<p>Improve the suction conditions.</p> <p>Clean the pump or suction pipe.</p>
The system's general protection cuts in.	Short circuit.	Check electrical system.
The pump rotates in the wrong direction when switched off.	<ul style="list-style-type: none"> a> The foot or the check valve has failed. b> Leakage in the suction pipe. 	<p>Check and replace check valve.</p> <p>Repair or replace the suction pipe.</p>

Fault	Probable cause	Possible Solution
The frequency of pump start-up is too high.	a. Leakage in the foot valve, check valve or system. b. Ruptured membrane or no air pre-charge in surge tank.	Repair or replace the components. See relevant instructions in surge tank's manual.
Vibration and noise.	a. Cavitation b. Make sure that pump and motor shafts are properly aligned. c. Worn motor bearings. d. Operation with frequency converter. e. Check vibration and noise damping devices	Reduce the required flow or improve the operating conditions of the pump (suction conditions, head, flow resistance, liquid temperature, viscosity,...etc.). Adjust the pump and/or motor shafts. Replace the bearings or the motor. Consult a qualified engineer from the supplier of the frequency converter. Replace vibration & noise dampers, if worn.

Maximum Operating Pressure and Inlet Pressure

50Hz Units	Stages	Maximum Operating Pressure		Stages	Maximum Inlet Pressures
				SBI/SBN 1	
	2 - 36	25 bar		2 - 36	10 bar
			SBI/SBN 3		
	2 - 36	25 bar		2 - 29 31 - 36	10 bar 15 bar
			SBI/SBN 5		
	2 - 36	25 bar		2 -16 18 - 36	10 bar 15 bar
			SBI/SBN 10		
	1 - 16 17 - 22	16 bar 25 bar		1 - 6 7 - 22	8 bar 10 bar
			SBI/SBN 15		
	1 - 10 12 - 17	16 bar 25 bar		1 - 3 4 -17	8 bar 10 bar
			SBI/SBN 20		
	1 - 10 12 - 17	16 bar 25 bar		1 - 3 4 -17	8 bar 10 bar
			SBI/SBN 32		
	1 - 7 8 - 14	16 bar 30 bar		1 - 4 5-10 11-14	4 bar 10 bar 15 bar
			SBI/SBN 45		
	1 - 5 6 - 11 12 -13	16 bar 30 bar 33 bar		1 - 2 3 - 5 6-13	4 bar 10 bar 15 bar
			SBI/SBN 64		
	(1-1) - 5 (6-2) - (8-1)	16 bar 30 bar		(1-1) - (2-2) (2-1) - (4-2) (4-1) - (8-1)	4 bar 10 bar 15 bar
			SBI/SBN 90		
	(1-1) - 6	20 bar		(1-1) - 3 4 - 6	8 bar 10 bar

60Hz Units	Stages	Maximum Operating Pressure		Stages	Maximum Inlet Pressures
				SBI/SBN 1	
	2 - 27	25 bar		2 - 25 27	10 bar 15 bar
			SBI/SBN 3		
	2 - 25	25 bar		2 - 15 17 - 25	10 bar 15 bar
			SBI/SBN 5		
	2 - 24	25 bar		2 - 9 10 - 24	10 bar 15 bar
			SBI/SBN 10		
	1 - 10 12 - 17	16 bar 25 bar		1 - 5 6 - 18	8 bar 10 bar
			SBI/SBN 15		
	1 - 8 9 - 12	16 bar 25 bar		1 - 2 3 - 12	8 bar 10 bar
			SBI/SBN 20		
	1 - 7 8 - 10	16 bar 25 bar		1 2 - 10	8 bar 10 bar
			SBI/SBN 32		
	(1-1) - 5 (6-2) - (10-2)	16 bar 30 bar		(1-1)-(2) (2) - (6) (7-2)-(10-2)	4 bar 10 bar 15 bar
			SBI/SBN 45		
	(1-1) - 4 (5-2)-7	16 bar 30 bar		(1-1) -1 2 - 3 4 - 7	4 bar 10 bar 15 bar
			SBI/SBN 64		
	(1-1) - 3 (4-2)-(5-2)	16 bar 30 bar		1 - 1 2 - 3 4 - 7	4 bar 10 bar 15 bar
			SBI/SBN 90		
	(1-1) - 6	20 bar		(1-1) -3 4 - 6	8 bar 10 bar

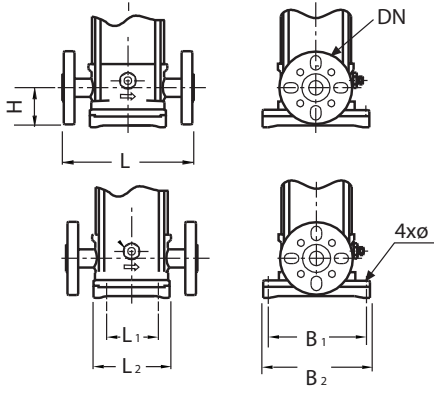

Pump Type	L mm	H mm	DN mm	L ₁ mm	L ₂ mm	B ₁ mm	B ₂ mm	Ø mm
SBI 1	250	75	25/32	100	150	180	220	14
SBI 3	250	75	25/32	100	150	180	220	14
SBI 5	250	75	25/32	100	150	180	220	14
SBI 10	280	80	40	130	200	215	248	14
SBI 15	300	90	50	130	200	215	248	14
SBI 20	300	90	50	130	200	215	248	14
SBI 32	320	105	65	170	225	240	297	14
SBI 45	365	140	80	190	251	265	330	14
SBI64	365	142	100	188	247	268	330	14
SBI90	380	140	100	199	260	280	345	14

SBI, SBN 1, 3, 5 Coupling Adjustment

1

2

3

M6-13Nm
M8-31Nm
M10-62Nm

4

M5-2.5Nm

SBI, SBN 10, 15, 20, 32, 45, 64 Coupling Adjustment

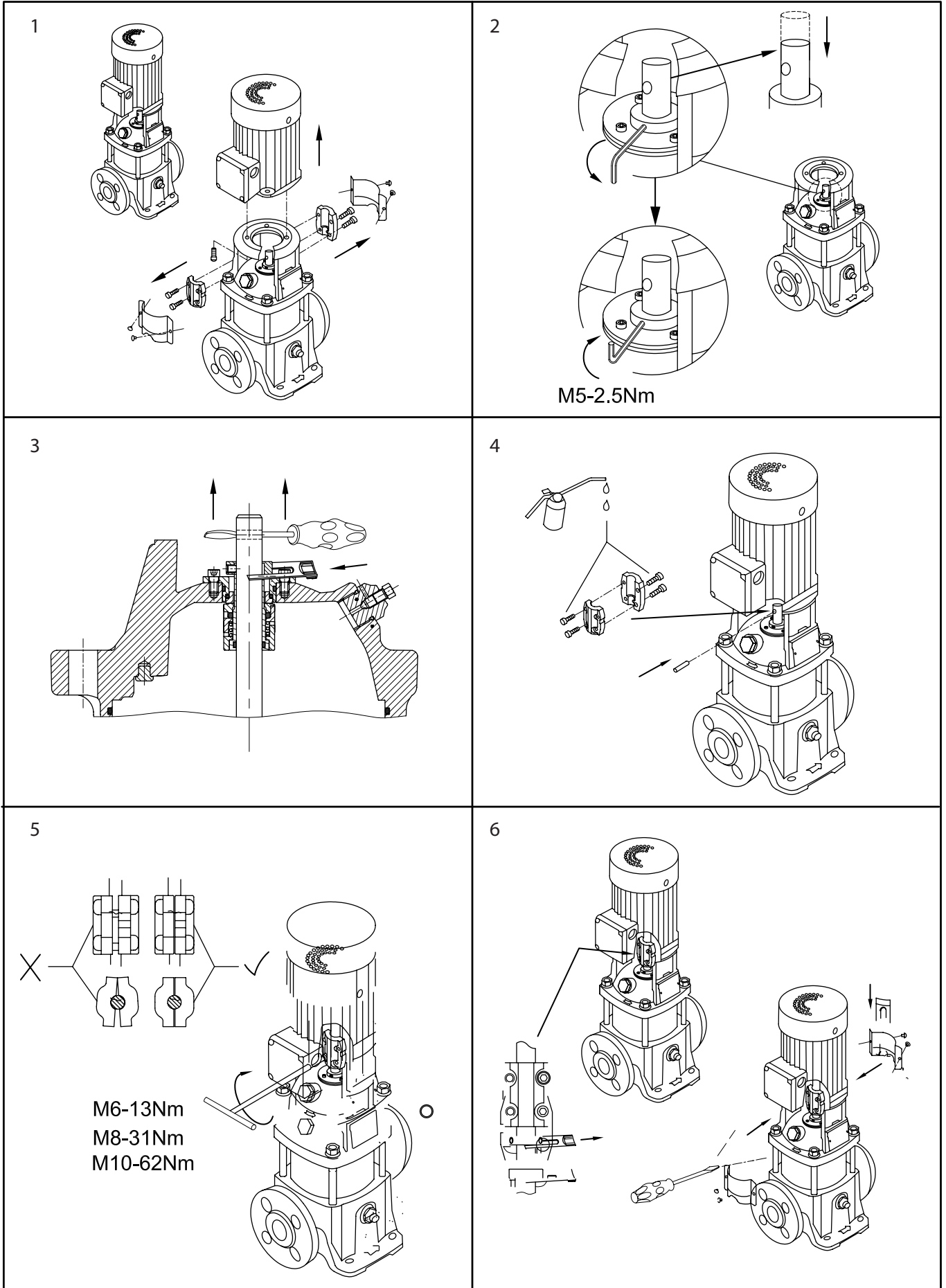



Telephone 131 PUMP

www.southerncross.pentair.com

*A division of Pentair Flow Control Pacific Pty Ltd
A.B.N. 83 000 922 690*
