

BIOX

STAINLESS STEEL SUBMERSIBLE DRAINAGE PUMP



OMNIA



FEATURES

Strong, durable and corrosion resistant stainless steel construction.

Drainage level to 45mm.*

Free passage to 40mm.

Vortex impeller.

Mechanical seal and lip seal.

Float switch.

Moisture sealed cable inlet.

Max head - 10m.

Max flow - 350lpm.

APPLICATIONS

- Disposal of domestic waste water including effluent water.
- Dewatering (clean water).

PUMP INFORMATION

Vertical, single-stage, submersible pump capable of pumping solids up to 20mm in diameter. 2" BSP (male) discharge port.

Pump casing:	304SS.
Motor body:	304SS.
Impeller:	304SS.
Motor shaft:	304SS.
Mechanical seal:	Graphite ceramic with lip seal.

OPERATING CONDITIONS

Drainage pump for the disposal of waste water, including rainwater lightly polluted (non-aggressive) and effluent waste liquids containing particles up to 40mm. Install pump vertically (hose connection possible).

Fluid:	Water.
Maximum water temperature:	40°C.
Minimum water temperature:	1°C.
Maximum submergence:	7m.
Minimum drainage level:	45mm*
Pump on level (fact. set)	400mm.
Pump off level (fact. set)	300mm.

*when operated manually.

ELECTRICAL DATA

Type	Type of current	Voltage $\pm 10\%$	Frequency Hz	Motor rating kW		RPM min	Current Ampere	Motor protection	Insulation class	IP rating	Cable length
				P1	P2						
Biox 300/10	1-phase	230	50	1.3	0.9	2850	5.8 A	Auto	F	IP 68	10 m

DIMENSIONS

Type	A	B	$\varnothing C$	Weight approx.	Packed L x W x H	Packed weight	Discharge branch	Free passage	Continuous operating temperature range
Biox 300/10	410	90	164	9 kg	225 x 190 x 460 mm	11 kg	2" BSP (male)	40mm	1°C - 40°C

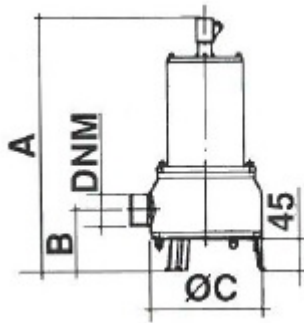

PERFORMANCE

Type	P/No	Delivery head [m]	1	2	3	4	5	6	7	8	9	10
Biox 300/10	P2091010	Flow rate capacity [lpm]	342	321	297	272	243	211	173	132	85	47

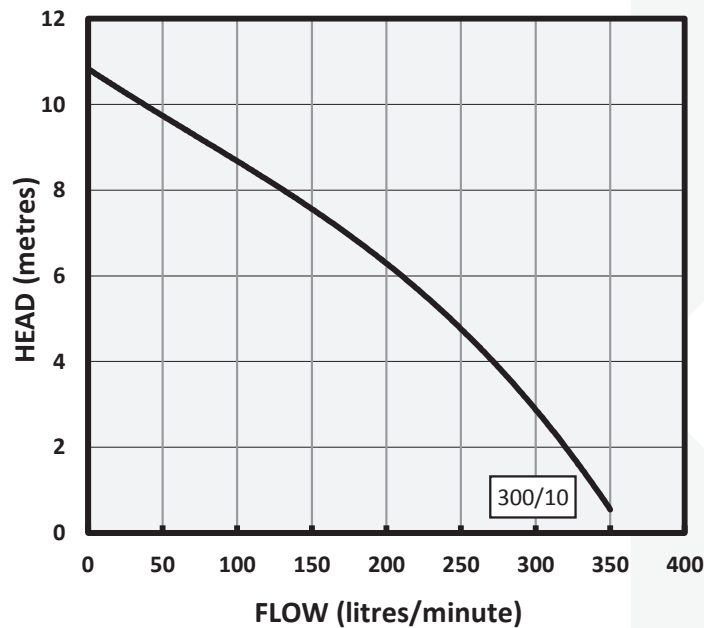

Head Office Pentair AU/NZ: 1-21 Monash Drive, Dandenong South, VIC 3175, Australia. www.pentair.com.au

All Pentair trademarks and logos are owned by Pentair, Ltd. All other brand or product names are trademarks or registered marks of their respective owners. Because we are continuously improving our products and services, Pentair reserves the right to change specifications without prior notice.

Pentair is an equal opportunity employer.

ABN 27 004 856 204 © 2012 Pentair, Ltd. All Rights Reserved.

© 2015 Pentair