

## US 73-253

### SUBMERSIBLE DRAINAGE PUMPS

30-40mm FREE PASSAGE



US 103 ES



#### FEATURES

- Safe to run dry.
- Free standing.
- 30-40 mm free passage.
- Controllable oil chamber.
- SiC mechanical seal independent of rotation direction.
- Replaceable moisture sealed cable inlet.
- Guide rail systems available.

#### APPLICATIONS

- Domestic waste water (without faecal matter).
- Rainwater.
- Drainage.
- Contaminated solids.
- Fibrous waste water.

#### PUMP CONSTRUCTION MATERIALS

Single stage submersible, open centrifugal impeller, volute casing with free inlet. US103 horizontal 1½" discharge branch (female thread).

<b>Pump casing:</b>	Cast iron.
<b>Impeller:</b>	Glass reinforced plastic.
<b>Wear plate:</b>	Glass reinforced plastic.
<b>Motor shaft:</b>	304SS.
<b>Mechanical seal:</b>	Silicon carbide.
<b>IP Rating:</b>	IP68.

#### OPERATING CONDITIONS

Drainage pumps US 73-253 are suitable for dealing with contaminated water and capable of handling solids up to 30 and 40 mm particle size without stones. Fibrous waste water as found in laundries and washing machines can be handled by this pump range.

## PERFORMANCE

Type	P/No	Delivery head H [m]	2	3	4	5	6	7	8	9	10	11	12
US 103 ES	JP44237	Flow rate Q [m <sup>3</sup> /h]	26	23	21	19	17	15	12	10	8	5	2

## DIMENSIONS

Type	Maximum Height x Width x Depth	Discharge branch	Free passage	Cable quality H07RN-F-	Cable length	Weight approx.	Code No.
US 103 ES	410 x 230 x 325 mm	1½"	30 mm	3G1,0	10 m	14,0 kg	

## ELECTRICAL DATA

Type	Type of current	Voltage Volt	Motor rating kW		RPM min-1	Current Ampere	Motor protection	Plug
			P1	P2				
US 103 ES	1-phase	1/N/PE~230	1,37	0,98	2700	6,0	integrated	Safety-

## PERFORMANCE CURVE

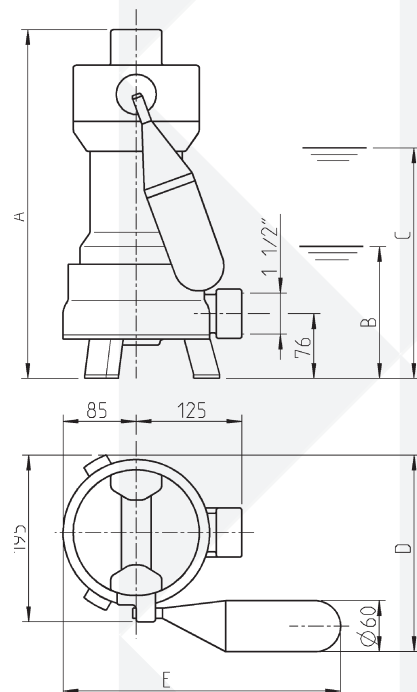
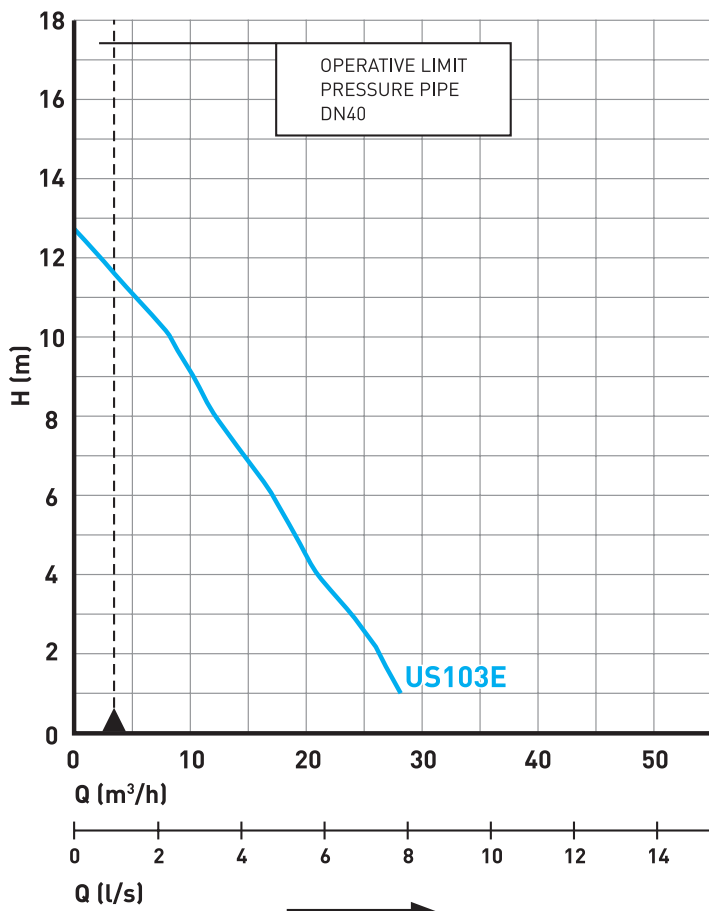

US	A	B	C	D	E
103	410	155	270	230	325
103*	410	135	185	255	280

\* With low level float.



Head Office Pentair AU/NZ: 1-21 Monash Drive, Dandenong South, VIC 3175, Australia. [www.pentair.com.au](http://www.pentair.com.au)

All Pentair trademarks and logos are owned by Pentair, Ltd. All other brand or product names are trademarks or registered marks of their respective owners. Because we are continuously improving our products and services, Pentair reserves the right to change specifications without prior notice. Pentair is an equal opportunity employer.

ABN 27 004 856 204 © 2012 Pentair, Ltd. All Rights Reserved.

© 2014 Pentair